

i Introduction to FY1003 Exam

Department of Physics, NTNU

Examination paper for FY1003 Electricity and Magnetism

Examination date: 29.05.2024

Examination time (from-to): 09:00-13:00

Permitted examination support material: C / Specified aids permitted. Definite, simple calculator allowed.

Books permitted:

"Matematisk formelsamling", Rottmann.

"Fysiske størrelse og enheter", Angell and Lian.

Academic contact during examination: Raffaella Cabriolu (phone: 96 972 328; email: raffaella.cabriolu@ntnu.no)

Administrative contact during examination: Julie Tetlimo (phone: 73 559 031; email: julie.tetlimo@ntnu.no).

OTHER INFORMATION

Do not open Inspira in multiple tabs, or log in on multiple devices, simultaneously. This may lead to errors in saving/submitted your answer.

Get an overview of the question set before you start answering the questions.

The student should also use PDF attached as a resource material to solve the exam.

Read the questions carefully and make your own assumptions. If a question is unclear/vague, make your own assumptions and specify them in your answer. The academic person is only contacted in case of errors or insufficiencies in the question set. Address an invigilator if you suspect errors or insufficiencies. Write down the question in advance.

Notifications: If there is a need to send a message to the candidates during the exam (e.g. if there is an error in the question set), this will be done by sending a notification in Inspira. A dialogue box will appear. You can re-read the notification by clicking the bell icon in the top right-hand corner of the screen.

Withdrawing from the exam: If you become ill or wish to submit a blank test/withdraw from the exam for another reason, go to the menu in the top right-hand corner and click "Submit blank". This cannot be undone, even if the test is still open.

Access to your answers: After the exam, you can find your answers in the archive in Inspira. Be aware that it may take a working day until any hand-written material is available in the archive.

1 Electric Field Lines (Chapter 21)

Consider the electric field lines of two conducting spheres shown in the figure below. What is the sign of the charge on the larger sphere A and on the smaller sphere B?

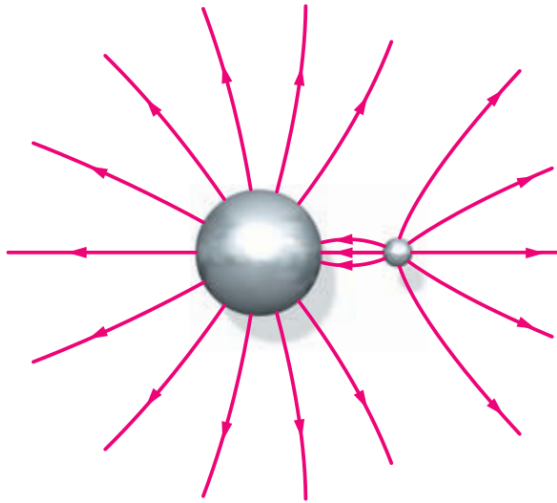

Select one alternative:

- Sphere B is negatively charged and sphere A is positively charged.
- Both spheres are negatively charged.
- Sphere A is negatively charged and sphere B is positively charged.
- Both spheres are positively charged.

Can you establish the relative magnitudes of the charges on the spheres?

Select one alternative

- The spheres are carrying the same amount of charge.
- They are not carrying any charges.
- The charge on sphere A is bigger than the charge on sphere B.
- The charge on sphere B is bigger than the charge on sphere A.

Maximum marks: 2

2 Potential of a conducting shell (Chapter 23)

An uncharged spherical conducting shell has an inner radius a and an outer radius b . A positive point charge $+q$ is located at the center of the shell. Assume that the potential V at the distance of the center $r = \infty$ is zero.

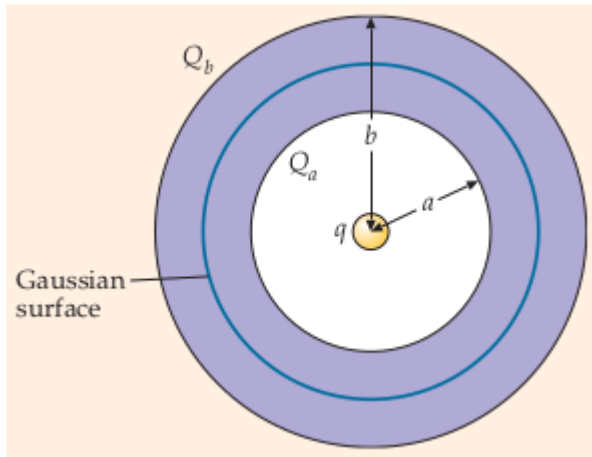

Find the charge in the inner surface, i.e. Q_{inner} , and on the outer surface, i.e. Q_{outer} , of the conductor.

Select one alternative:

- $Q_{\text{inner}} = Q_{\text{outer}} = -q$
- $Q_{\text{inner}} = +q; Q_{\text{outer}} = -q$
- $Q_{\text{inner}} = -q; Q_{\text{outer}} = +q$
- $Q_{\text{inner}} = +q; Q_{\text{outer}} = -q$
- $Q_{\text{inner}} = Q_{\text{outer}} = +q$

Calculate the potential at points where $r > b$.

Select one alternative:

$V = \frac{k 2q}{r}$

$V = \frac{kq}{r^2}$

$V = \frac{kq}{r}$

$V = \frac{kq}{b}$

$V = 0$

Calculate the potential at points where $a < r < b$.

Select one alternative:

$V = k\left(\frac{q}{r} - \frac{q}{b} + \frac{q}{a}\right)$

$V = k\left(\frac{q}{r} - \frac{q}{a} + \frac{q}{b}\right)$

$V = k\left(\frac{q}{r-b-a}\right)$

$V = \frac{kq}{a}$

$V = \frac{kq}{b}$

$V = \frac{kq}{r}$

Calculate the potential at points where $0 < r < a$.

Select one alternative:

- $V = k\left(\frac{-q}{b} + \frac{q}{a}\right)$
- $V = k\left(\frac{q}{r} - \frac{q}{a} + \frac{q}{b}\right)$
- None of the alternatives.
- $V = k\frac{q}{r}$
- $V = k\left(\frac{q}{r} - \frac{q}{a} + \frac{q}{b}\right)$

Maximum marks: 4

3 Electric field calculations (Chapter 21)

Consider the figure below.

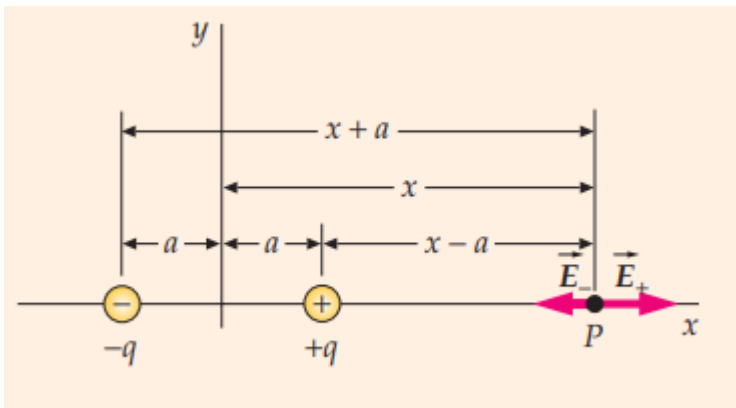

Find the expression for the total electric field on the x axis at an arbitrary point $x > a$.

Select one alternative:

- $\vec{E}_x = kq \frac{4ax}{(x^2 - a^2)^2} \hat{i}$
- $\vec{E}_x = kq \frac{4ax}{x} \hat{i}$
- $\vec{E}_x = kq \frac{4}{x^3} \hat{i}$
- $\vec{E}_x = -kq \frac{4ax}{(x^2 + a^2)^2} \hat{i}$
- $\vec{E}_x = kq 4ax \hat{i}$

What is the electric field at a point $x \gg a$?

Select one or more alternatives

- $\vec{E}_x = kqa \frac{4}{x^3} \hat{i}$
- $\vec{E}_x = kqax^3 \hat{i}$
- $\vec{E}_x = kqa \frac{4}{x^2} \hat{i}$
- $\vec{E}_x = kqa \frac{4}{(x+y)^3} \hat{i}$

Consider the case of $q = 1.0$ nC and $a = 1.0$ m. Which graph among the plots below represent the electric field E_x versus x for all distances x ?

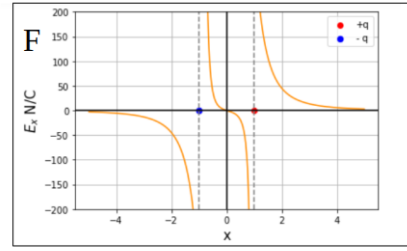
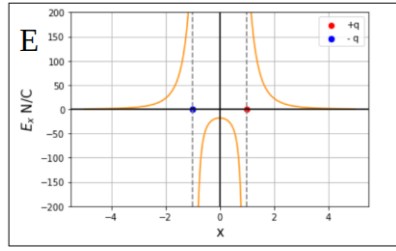
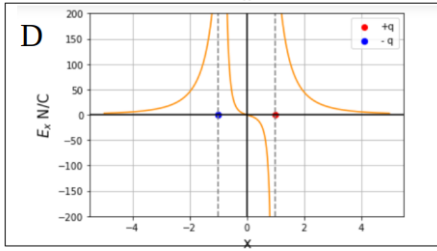
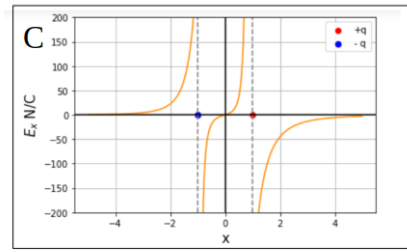
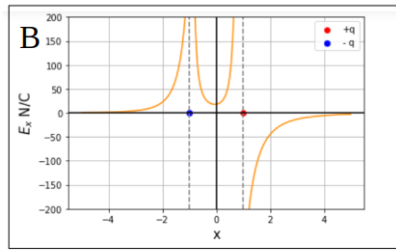
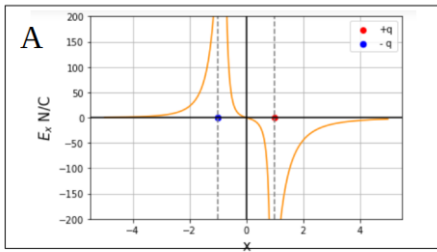

Select one alternatives

- D
- A
- B
- F
- C
- E

Maximum marks: 3

4 DC currents (Chapter 26)

In the circuit below, the DC voltage source V_0 has been connected for a sufficient amount of time such that the currents in the circuit and the charges on the capacitors no longer change.

Determine the current I , as well as the charges Q_1 , Q_2 , Q_3 , and Q_4 on the capacitors labeled 1, 2, 3, and 4 respectively.

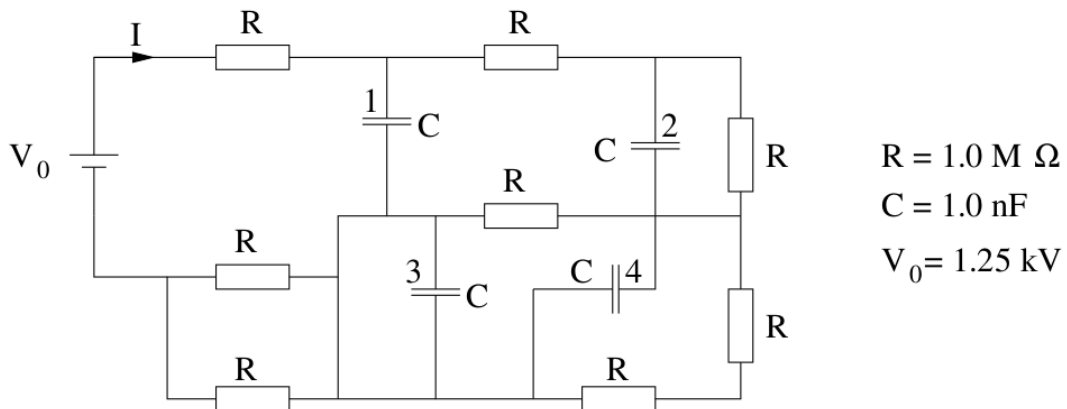

Select the correct current I :

- 0.3 MA
- 4 A
- 0.16 mA
- 10 mA
- 0.3 mA

Select the correct values for the charges Q_1 , Q_2 , Q_3 , and Q_4 on the capacitors labeled 1, 2, 3, and 4 respectively.

- $Q_1 = 0.2 \mu C, Q_2 = 0.3 \mu C, Q_3 = 0.8, Q_4 = 0 \mu C,$
- $Q_1 = 0.8 \mu C, Q_2 = 0.3 \mu C, Q_3 = 0, Q_4 = 0.2 \mu C,$
- $Q_1 = 0.5 \mu C, Q_2 = 0.3 \mu C, Q_3 = 0.8, Q_4 = 0.2 \mu C,$
- $Q_1 = 0.4 \mu C, Q_2 = 0.4 \mu C, Q_3 = 0, Q_4 = 0.5 \mu C,$
- None of the given options.

5 Coil in a magnetic field (Chapter 27)

A rectangular coil comprises 200 turns of wire of dimensions $10\text{ cm} \times 15\text{ cm}$. The coil is placed in a uniform magnetic field of magnitude 0.16 T directed such that the field lines make an angle $\theta = 25^\circ$ with the normal to the plane of the coil. Calculate the magnitude of the torque τ on the coil if a current of 120 mA flows in it.

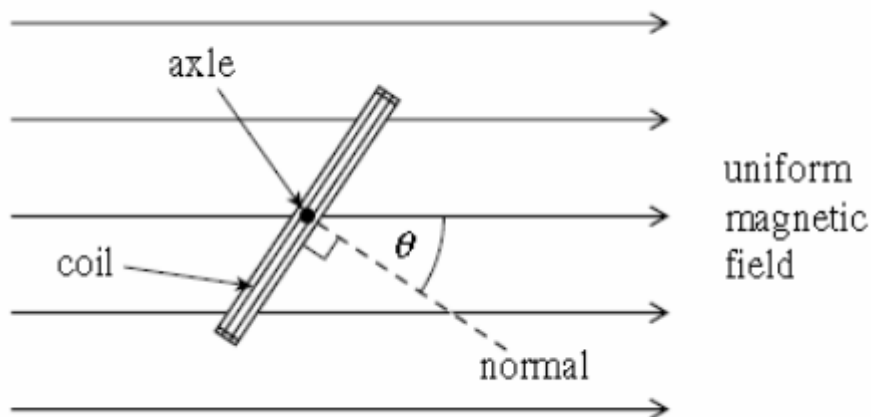

Select one alternative:

- $\tau = 0.024\text{ Nm}$
- $\tau = 0.052\text{ Nm}$
- $\tau = 24.34\text{ Nm}$
- $\tau = 243.43\text{ Nm}$
- $\tau = 52.20\text{ Nm}$

6 Torque of the force (Chapter 27)

A wire carrying a current of 3.5 A splits into two paths, forming a rectangular loop with side dimensions $2d \times l$, where $2d = 3 \text{ cm}$ and $l = 4 \text{ cm}$ as shown in the figure below. The wire on the left side, which has a length l , carries the current I_1 and has a resistance of 2.0Ω , while the wire on the right side, also of length l , carries the current I_2 and has a resistance of 5.0Ω . The resistance of the 3 cm sides are negligible. The plane of the rectangle is parallel to a uniform magnetic field 2.4 T.

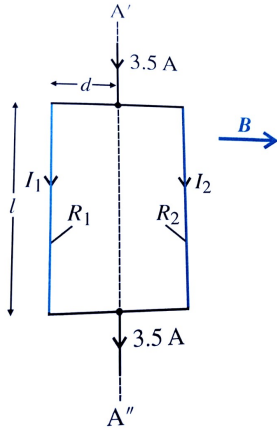

What are the currents I_1 and I_2 on the left hand side and right hand side straight wires?

Select one alternative:

- $I_1 = 0.5 \text{ A}, I_2 = 3.0 \text{ A}$
- $I_1 = I_2 = 3.5 \text{ A}$
- $I_1 = 1.5 \text{ A}, I_2 = 2.0 \text{ A}$
- $I_1 = 0.5 \text{ A}, I_2 = 0.2 \text{ A}$
- $I_1 = 2.5 \text{ A}, I_2 = 1.0 \text{ A}$

What are the magnitude of the magnetic forces, i.e. F_1 and F_2 , on the left and right side wires?

Select one alternative

- $F_1 = 0.048 \text{ N}, F_2 = 0.0192 \text{ N}$
- $F_1 = 0.18 \text{ N}, F_2 = 0.0072 \text{ N}$
- $F_1 = 0.144 \text{ N}, F_2 = 0.192 \text{ N}$
- $F_1 = 0.336 \text{ N}, F_2 = 0.336 \text{ N}$
- $F_1 = 0.24 \text{ N}, F_2 = 0.096 \text{ N}$

What is the magnitude of the net torque on the rectangular loop?

Select one alternative

- $\tau = 0.0004N \cdot m$
- $\tau = 0.00432N \cdot m$
- $\tau = 0$
- $\tau = 0.0022N \cdot m$
- $\tau = 0.0007N \cdot m$

When viewed along the direction of the current I , what is the direction of torque?

Select one alternative

- The net force is not null but the torque of the force is null.
- The net force is null and also the torque of the force.
- clockwise
- counterclockwise

Maximum marks: 4

7 Ampère's Law (Chapter 28)

Consider two coaxial conducting wires in the illustration below. The inner wire has a radius a , and the outer conducting shell has an inner radius b and a thickness equal to $c-b$. Calculate the magnetic field strength as a function of the distance r from the axis of the wires using Ampère's law. The current flows in the central conductor and returns in the opposite direction in the outer conductor, as shown by the arrows in the illustration.

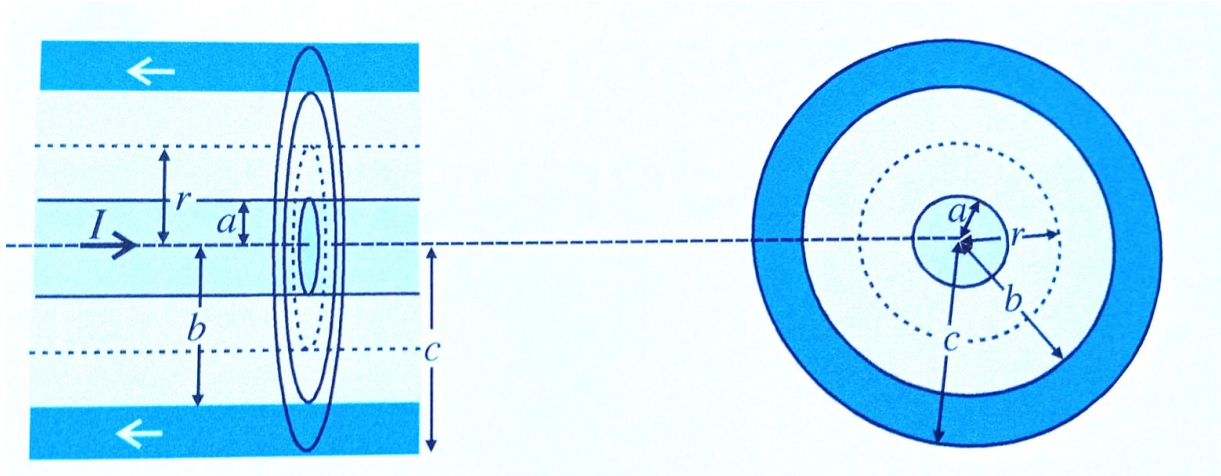

What is the magnitude of the magnetic field, B , at distances $r < a$?

Select one alternative:

- $B = \frac{\mu_0 I}{2\pi(a-r)^2}$
- $B = 0$
- $B = \frac{\mu_0 I}{2\pi r^2}$
- $B = \frac{\mu_0 I}{2\pi r}$
- $B = \frac{\mu_0 I r}{2\pi a^2}$

What is the magnetic field magnitude at distances $a < r < b$?

Select one alternative

- $B = \frac{\mu_0 I}{2\pi r}$
- $B = 0$
- $B = \frac{\mu_0 I}{2\pi(a+r)^2}$
- $B = \frac{\mu_0 I r}{2\pi a}$
- $B = \frac{\mu_0 I(b-a)}{2\pi r}$

What is the magnetic field at distances $b < r < c$?

Select one alternative

- $B = \frac{\mu_0 I r^2}{2\pi r(c^2 - b^2)}$
- $B = \frac{\mu_0 I(c^2 - r^2)}{2\pi r(c^2 - b^2)}$
- $B = \frac{\mu_0 I b^2}{2\pi r c^2}$
- $B = \frac{\mu_0 I c^2}{2\pi r^2}$
- $B = 0$

What is the magnetic field at distances $r > c$?

Select one alternative

$B = \frac{\mu_0 I (c^2 - r^2)}{2\pi r}$

$B = 0$

$B = \frac{\mu_0 I}{2\pi(r^2 - c^2)}$

$B = \frac{\mu_0 I}{2\pi r}$

$B = \frac{\mu_0 I (c^2 - a^2)}{2\pi r (c^2 - b^2)}$

Maximum marks: 4

8 Discharging a capacitor (Chapter 26)

In the circuit below, after charging the capacitor, the battery has been removed. When the switch is closed ($t=0\text{s}$), the potential difference across the capacitor is 100 V. At $t=10\text{ s}$, the potential difference across the capacitor is measured to be 1.0V.

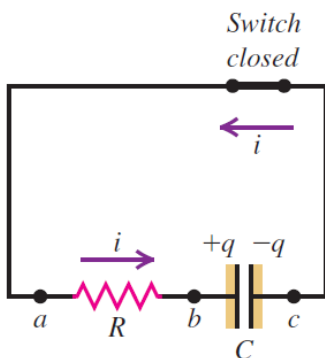

Determine the time constant of the circuit.

Select one alternative:

- 20 s
- 217 s
- 10 s
- 17 s
- 2.17 s

Determine the potential difference across the capacitor at time $t = 17\text{ s}$

Select one alternative

- 42.74 V
- 92.46 V
- 0.02 V
- 18.27 V
- 0.04 V

By what factor should the resistance be changed to triple the potential difference at time $t=17\text{s}$?

Select one alternative

- 1.17
- 13.03
- 79.40
- 7.68
- 31.51

Maximum marks: 3

9 Gauss Law Conceptual (Chapter 22)

Your friend likes to rub his feet on the carpet and then touch you to give you a shock. While trying to escape the shocks, you find a hollow metal cylinder large enough to enter inside. In which of the following scenarios will you not be shocked?

Select one alternative:

- Your charged brother is inside touching the inner metal surface and you are outside, touching the outer metal surface.
- You step inside the cylinder, making contact with the inner surface, while your charged brother touches the outer metal surface.
- Both of you are outside the cylinder, touching its outer metal surface but not touching each other directly.

Consider the charge distribution shown in the Figure below. Which charges contribute to the total electric field at a chosen point on the surface S' ?

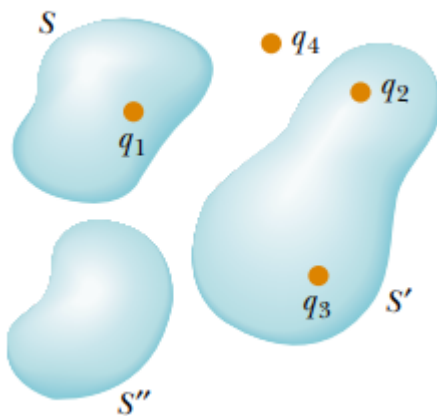

Select one alternative

- q_4
- q_1 and q_4
- q_1
- All four charges.
- None of the charges.
- q_2 and q_3

Which of the following statements is true if the charge in the figure below were inside but not at the center of the spherical Gaussian surface?

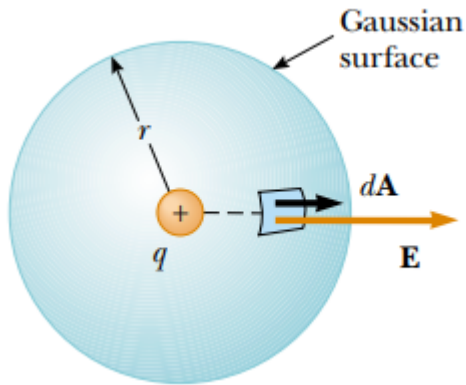

Select one alternative

- The Gauss Law would still be valid, however, the Electric field would not be everywhere perpendicular to the surface and the situation would not possess enough symmetry to evaluate the electric field.
- The Gauss Law is valid, and the Electric field would be perpendicular to the Gaussian surface and have magnitude $E = k\frac{q}{r^2}$, with r indicating the distance from the center of the Gaussian sphere.
- The Gauss Law would not be valid, and the electric field magnitude would still be $E = k\frac{q}{r^2}$, with r indicating the distance from the center of the Gaussian sphere.
- The Gauss law will not be valid and the Electric field could not be evaluated using it.

Maximum marks: 3

10 Gauss Law (Chapter 22)

A solid, insulating sphere of radius a has a uniform charge density ρ and a total charge Q . Concentric with this sphere is an uncharged, conducting hollow sphere with inner and outer radii b and c , as shown in the figure below.

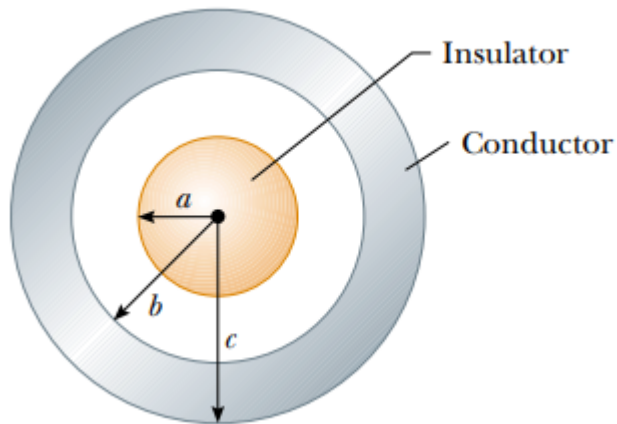

What is the magnitude of the electric field at an arbitrary point where $r < a$.

Select one alternative:

- $E = k \frac{Q}{a^2}$
- $E = 0$
- $E = k \frac{Q}{(a-r)^2}$
- $E = k \frac{Q}{r^2}$
- $E = k \frac{Qr}{a^3}$

What is the magnitude of the electric field at an arbitrary point where $a < r < b$.

Select one alternative

- $E = k \frac{Q}{r^2}$
- $E = k \frac{Q}{(a+r)^2}$
- $E = k \frac{Qr}{a^3}$
- $E = 0$
- $E = k \frac{Qr}{(b-a)^3}$

Find the magnitude of the electric field at an arbitrary point where $b < r < c$.

Select one alternative

- $E = k \frac{Qr}{(c-r)^3}$
- $E = k \frac{Q}{r^2}$
- $E = 0$
- $E = k \frac{Q}{(c-r)^2}$
- $E = k \frac{Qr}{c^3}$

What is the magnitude of the electric field at an arbitrary point where $r > c$.

Select one alternative

- $E = k \frac{Q}{(r-c)^2}$
- $E = k \frac{Q}{r^2}$
- $E = 0$
- $E = k \frac{Qc}{r^3}$
- $E = k \frac{Qr}{(c-b+a)^3}$

Determine the induced charge on the inner and outer surfaces, i.e. Q_{inner} and Q_{outer} , of the hollow sphere.

Select one alternative

- $Q_{\text{inner}} = -Q, Q_{\text{outer}} = 0$
- $Q_{\text{inner}} = -Q, Q_{\text{outer}} = +Q$
- $Q_{\text{inner}} = Q_{\text{outer}} = -Q$
- $Q_{\text{inner}} = Q_{\text{outer}} = +Q$
- $Q_{\text{inner}} = Q_{\text{outer}} = 0$
- $Q_{\text{inner}} = 0, Q_{\text{outer}} = +Q$

Consider now the situation with the total charge Q_a on the sphere with radius a . The outer conductor has now been charged and it has a total charge Q_b as in the illustration below. Answer the following questions.

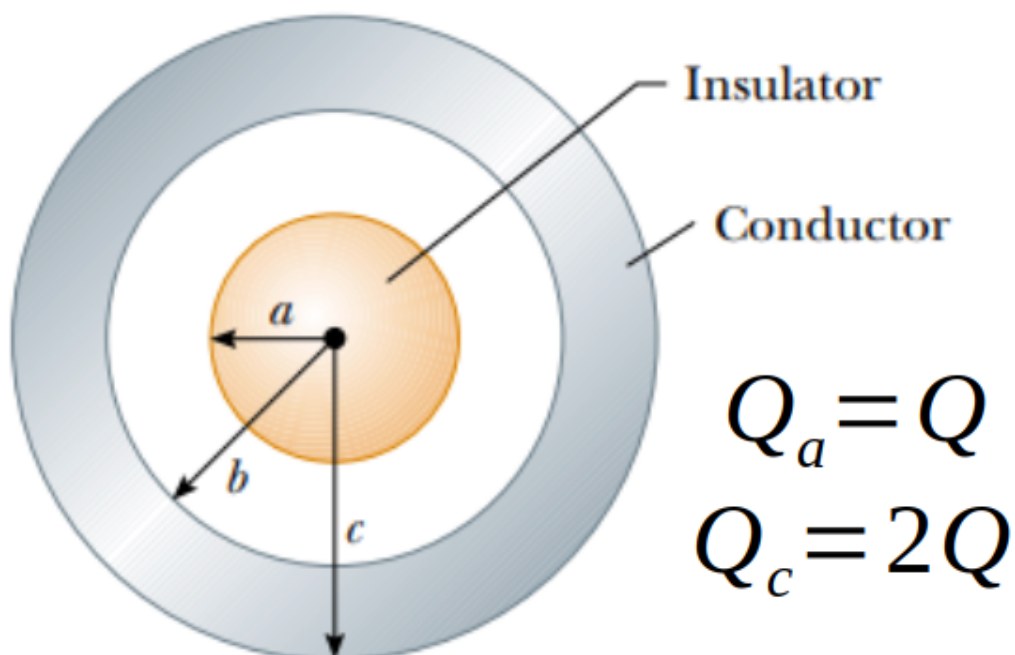

What is now the electric field magnitude at points where $b < r < c$?

Select one alternative

- $E = \frac{k3Q}{(c-r)^2}$
- $E = \frac{k(3Q)r}{c^3}$
- $E = \frac{k3Qr}{(c-r)^3}$
- $E = \frac{k3Q(r-b)^3}{r^2(c-r)^3} + \frac{kQ}{r^2}$
- $E = 0$
- $E = \frac{kQ}{r^2}$

What is now the Electric field at points where $r > c$?

Select one alternative

- $E = k\frac{Q}{r^2}$
- $E = k\frac{3Qr}{c^3}$
- $E = k\frac{3Q}{r^2}$
- $E = 0$
- $E = k\frac{Qr}{(c-r)^3}$
- $E = k\frac{3Q}{(c-r)^2}$

What is the total charge on the surface of conductor?

Select one alternative

4Q

3Q

2Q

-Q

0

Maximum marks: 8

11 Electromagnetic Waves (Chapter 32)

An FM radio station transmits at the frequency 100 MHz.



What is the transmitting wavelength of this radio wave?

Select one alternative:

- $1.5 \cdot 10^3 m$
- $3.0 \cdot 10^6 m$
- $1.5 \cdot 10^9 m$
- $3.0 \cdot 10^{-6} m$
- $3.0 m$

Assume that this FM signal is a sinusoidal wave propagating in the z direction with the electric field pointing always in the x direction with magnitude $E_0 = 2.0 \text{ V/m}$.

What is the magnitude of the magnetic field?

Select one alternative

- $4.5 \times 10^{-8}T$
- $6.7 \times 10^{-9}T$
- $3.33 \times 10^{-9}T$
- $8.8 \times 10^{-2}T$
- $2.9 \times 10^{-2}T$
- $2.9 \times 10^{-4}T$

What is the direction of the magnetic field?

Select one alternative

- Parallel to the z direction.
- Parallel to the y direction.
- Parallel to the x direction.
- It has x and y components.
- It has y and z components.

Maximum marks: 3

12 Displacement Current (Chapter 29)

A capacitor is made of two circular plates, each with an area of 100 cm^2 and radius $r = r_0$. The capacitor has a capacitance of 30 pF , and it is connected in series to a 70 V battery and to a $2.0 \text{ }\Omega$ resistor. At the instant $t = t_0$, the circuit is closed, the electric field between the plates is changing most rapidly.

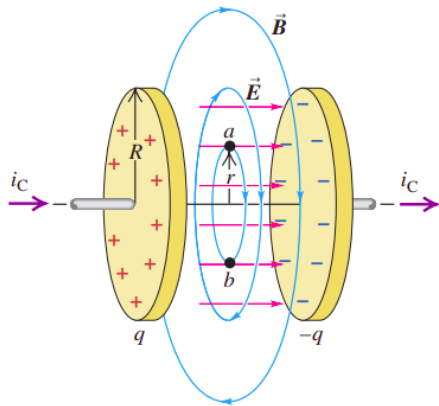

What is the current into the plates at this instant $t = t_0$?

Select one alternative:

- 0
- 35 A
- 20 A
- 10 A
- 0.2 A

What is the rate of change of the electric field between the plates?

Select one alternative

- 0
- $4 \times 10^{12} \text{ V/m} \cdot \text{s}$
- $1.14 \times 10^{14} \text{ V/m} \cdot \text{s}$
- $2.28 \times 10^{14} \text{ V/m} \cdot \text{s}$
- $4 \times 10^{14} \text{ V/m} \cdot \text{s}$

What is the magnitude of the magnetic field induced between the plates of the capacitor?
Assume that the electric field is uniform at any instant between the plates, it is zero at all points beyond the edges of the plates, and that it is perpendicular to the field lines of B .

Select one alternative

- $1.2 \times 10^{-4}T$
- 12×10^4T
- $5 \times 10^{-2}T$
- 0
- $5 \times 10^{-4}T$

Maximum marks: 3

13 Inductance (Chapter 30)

Consider the coaxial cable whose inner conductor has a radius r_1 and outer conductor has a radius r_2 , as in the figure below. Assume that the conductors are very thin, so that the magnetic field inside them can be ignored. The conductors carry equal currents in opposite directions.

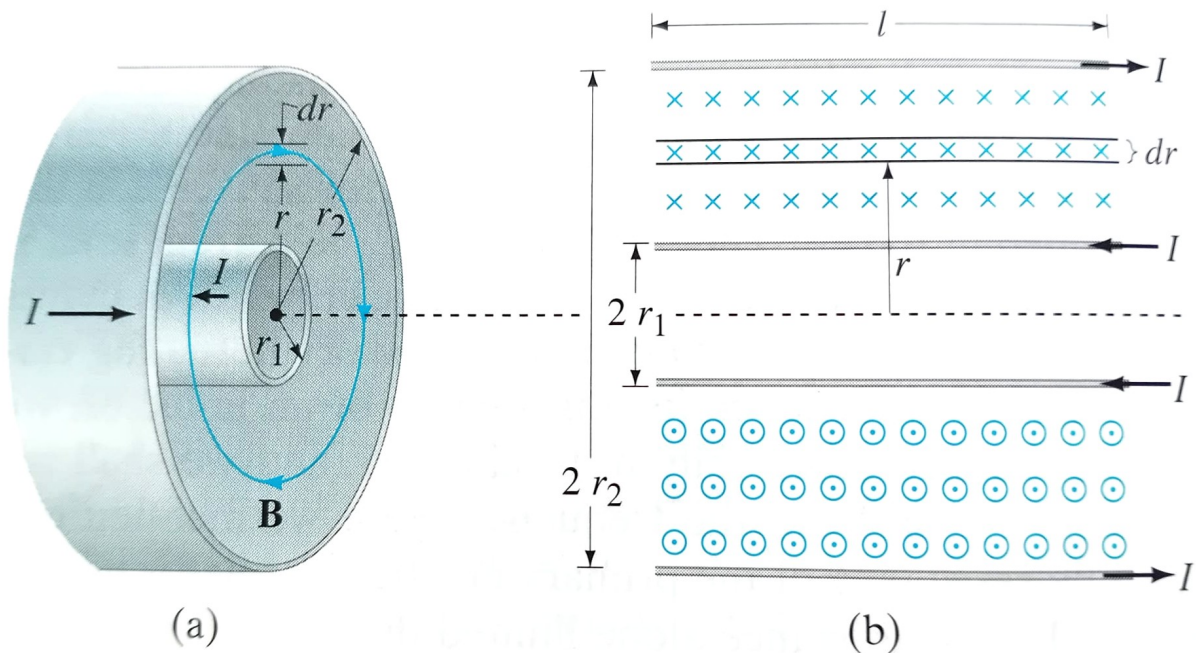

Calculate the inductance of the cable considering the magnetic flux through the rectangle of width dr and length l along the cable, as in the figure above.

Select one alternative:

$L = \frac{\mu_0 l}{2\pi} r$

$L = \frac{\mu_0 l}{2\pi} \ln \frac{r_2}{r_1}$

None of the options is correct.

$L = \frac{\mu_0 l r}{2\pi} \ln \frac{r_2}{r_1}$

$L = \frac{\mu_0 l}{2\pi} \ln \frac{r_1}{r_2}$

Maximum marks: 1

14 Power station (Chapter 31)

An average of 120 kW of electric power is sent to a small town from a power plant 10 Km away. The transmission lines have a total resistance of 0.40Ω . This resistance does not include the load of the town.

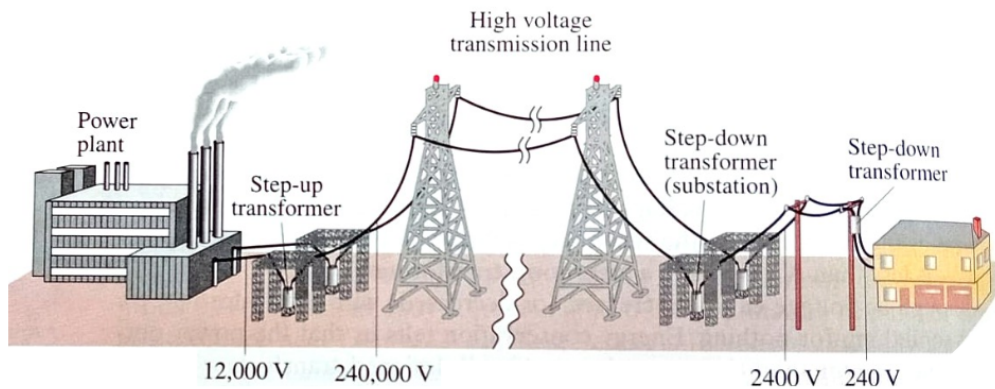

What is the power loss if the power is transmitted at 240 V?

Select one alternative:

- 200 W
- 500 kW
- 200 kW
- 100 W
- 100 kW

What is the power loss if the power is transmitted at 24000 V?

Select one alternative

- 10 W
- 200 kW
- 500 W
- 100 W
- 200 kW

Which of the following conclusions can you draw from the exercise above?

The great advantage of the ac is that the voltage can be stepped up or down by a transformer.

Select one alternative

- However, a transformer can only transform voltages, not currents.
- However, a transformer can only transform voltages, not resistances.
- This exercise shows that it is convenient to step up the voltage prior to transmission to increase the power loss.
- This exercise shows that it is convenient to step up the voltage prior to transmission to reduce the power loss.
- This exercise shows that it is convenient to step down the voltage prior transmission to reduce the power loss.

Maximum marks: 3

15 Alternatic Current RLC circuits (Chapter 31)

Which of the following sentences are true for alternating RLC series circuits?

Select one or more alternatives:

- At resonance, the current is in phase with the voltage applied.
- The phase angle does not depend on the resistance.
- Capacitors tend to pass low-frequency current.
- Inductors tend to pass high-frequency current.
- For pure resistors, the average power is zero.
- At resonance, the impedance equals the resistance R .
- Increasing the resistance of the resistor in an AC LRC circuit results in a higher and sharper peak in the current near the resonance frequency.

Maximum marks: 2